

3 Off-line Partial Discharge (PD) Test Details

3.1 Damped Alternating Current (DAC) Voltage

The Off-Line Partial Discharge (PD) with Damped Alternating Current (DAC) Voltage. Test was performed **according to IEEE 400.4-2015**. The DAC voltage testing is one of the alternative methods of ac voltage testing and is applicable for a broad range of medium-voltage (MV), high-voltage (HV), and extra-high-voltage (EHV) cable types. As the DAC test procedure has been used for several years for diagnostic, maintenance and acceptance (commissioning) tests, it provides a method of evaluation of the insulation condition and helps to fill the need for more complete information on the condition of cable systems. The frequency range of DAC voltage testing is in the from 20 Hz to 500 Hz. The DAC test circuit basically consists of a HV voltage source generating an increasing unipolar voltage (See Figure 3-1) a HV inductor in the range of several [H], a capacitive test object and a suitable HV switch (See Figure 3-2). The capacitive test object can consist of one or more capacitive test objects, such as power cables or generators. Even though a cable has distributed parameters, for simplification a lumped capacitor model is used. When the unipolar charging voltage has reached the maximum value V_T the HV switch is closed, generating a damped alternating voltage on the capacitive test object. The damping factor depends on the loss characteristics of the test circuit and the test object. The DAC natural frequency (is determined by the values of the HV inductor and the capacitance of the test object. Below a certain capacitance value of the test object, the natural frequency of the oscillation will exceed acceptable values. For these cases an additional HV storage capacitor can be connected in parallel to the circuit.

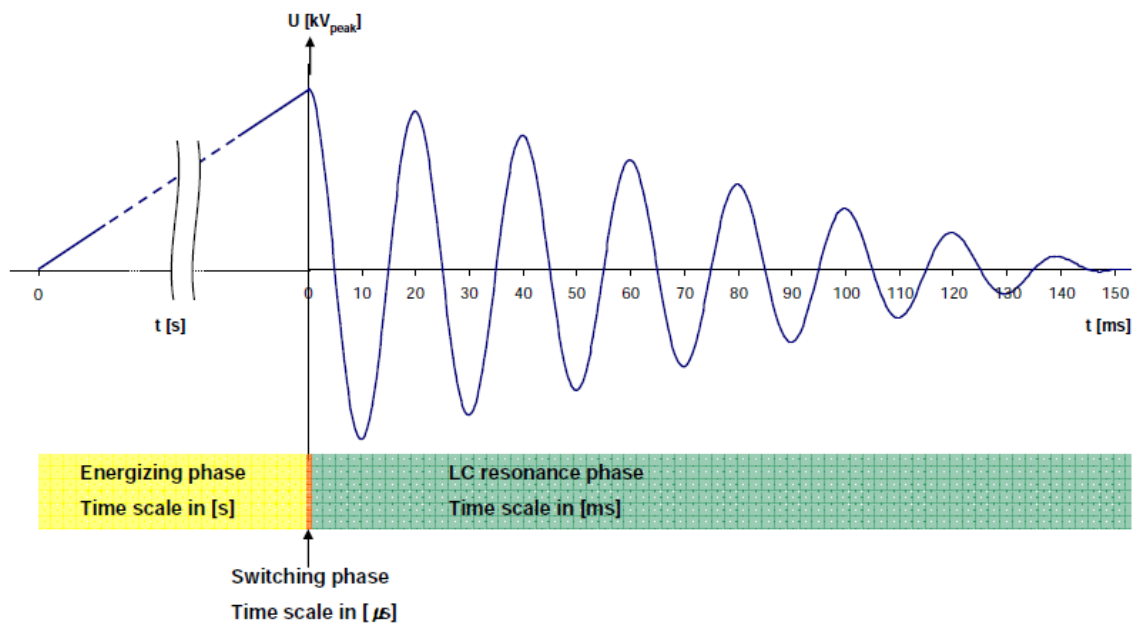
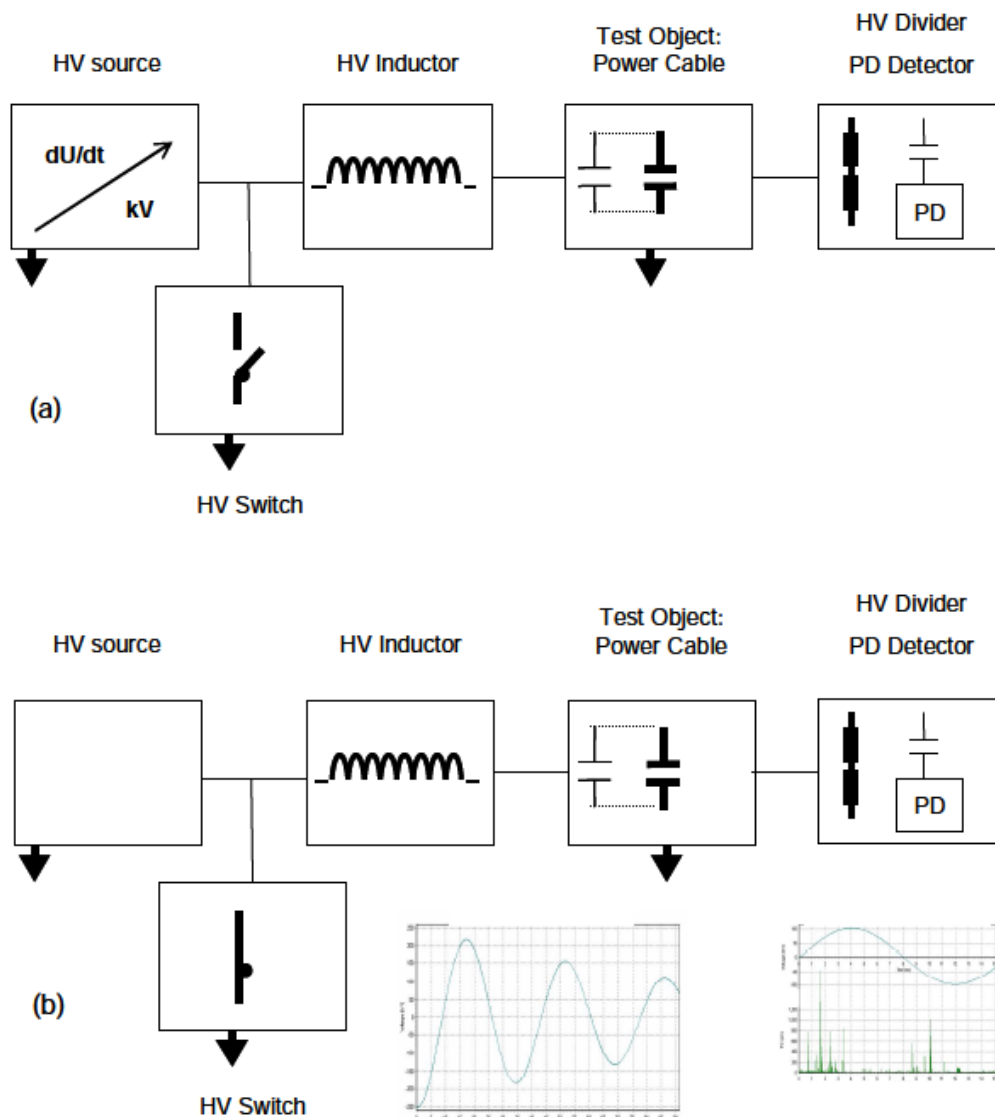

Figure 3-1 HV voltage source charge and discharge voltage for testing



(a) circuit-charging phase and (b) LC-oscillation phase. In case of monitored test, such Parameters as PDs and DF can be measured.

Figure 3-2 DAC test circuit

DAC Advantages:

- The DAC voltage withstand test by applying a defined number of DAC excitations gives the possibility to produce a breakdown or to initiate PD occurrences in insulation defects.
- Can give the possibility to detect various defects in the insulation that will be detrimental to the cable system under service conditions, without creating new defects or causing any significant aging of healthy insulation.
- Gives PD patterns and parameters similarity between the results of DAC tests and continuous power frequency.
- Has low system complexity, is lightweight, and is easy to handle and operate.

- Requires relatively low input power of the DAC test equipment for testing long lengths of cable.
- Can measure diagnostic testing by using partial discharge (Figure 3-3) and $\tan \delta$.
- Can apply voltage withstand test.

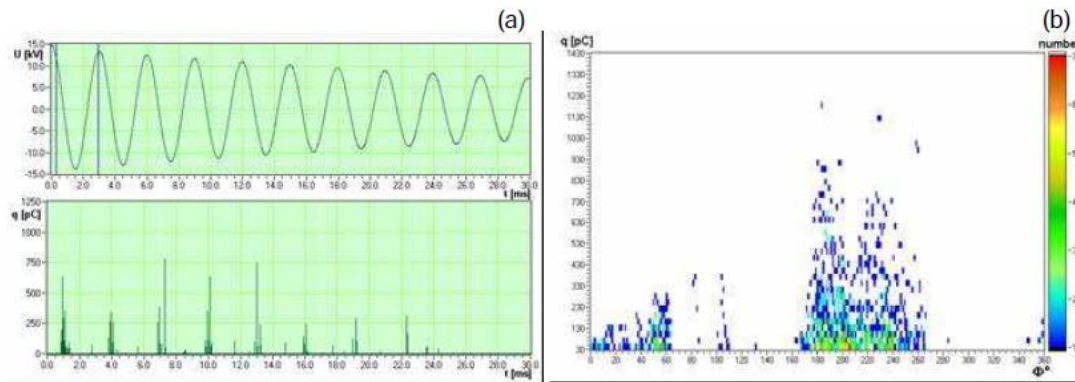

Figure 3-3 — Example of PD patterns at DAC test voltages : (a) 2-dimensional pattern with the PD occurrence q versus the test voltage U on identical time base; (b) 3-dimensional pattern with the PD occurrence represented in discharge magnitude, phase angle and number of PDs (by colour).